

RS 5-19 GEN·3

RS



GEHL®

Capacities		Metric	Imperial
Max. capacity		2494.76 kg	5500 lb
Max. lifting height		5.82 m	19 ft 1 in
Max. outreach		3.35 m	11 ft
Weight and dimensions			
Length to face of forks	l2	3.76 m	12 ft 4 in
Overall width	b1	1.80 m	5 ft 11 in
Overall height	h17	1.93 m	6 ft 4 in
Wheelbase	y	2.29 m	7 ft 6 in
Ground clearance	m4	266 mm	10 in
Overall cab width	b4	711 mm	28 in
Tilt-up angle	a4	12 °	12 °
Tilt-down angle	a5	100 °	100 °
External turning radius	Wa3	3.35 m	11 ft
Unladen weight (with forks)		4427 kg	9760 lb
Overall weight		4535.92 kg	10000 lb
Standard tyres		12 x 16.5	12 x 16.5
Performances			
Lifting		8 s	8 s
Lowering		5 s	5 s
Extension		7 s	7 s
Retraction		6 s	6 s
Engine			
Engine brand		Yanmar	Yanmar
Engine norm		Tier 4 final	Tier 4 final
Engine model		4TNV98C	4TNV98C
I.C. Engine power rating - Power (kW)		69 Hp / 50.10 kW	69 Hp / 50.10 kW
Max. torque / Engine rotation		235 Nm @ 1625 rpm	173 ft/lbs @ 1625 rpm
Transmission			
Transmission type		Hydrostatic	Hydrostatic
Number of gears (forward / reverse)		2 / 2	2 / 2
Max. travel speed		24 km/h	15 mi/h
Parking brake		SAHR	SAHR
Service brake		Wet disc brakes	Wet disc brakes
Axle Manufacturer		Dana	Dana
Hydraulics			
Hydraulic pump type		Gear pump	Gear pump
Hydraulic flow / Pressure		83.28 l/min-231 bar	22 US gpm-3350 PSI
Tank capacities			
Engine oil		9 l	2 US gal
Hydraulic oil		68.14 l	18 US gal
Fuel tank		64.35 l	17 US gal
Miscellaneous			
Steering wheels (front / rear)		2 / 2	2 / 2
Drive wheels (front / rear)		2 / 2	2 / 2
Safety cab homologation		ROPS/FOPS	ROPS/FOPS
Controls		Single joystick with FNR	Single joystick with FNR

RS 5-19 Gen: 3 - Load chart

Machine on tyres with forks Imperial

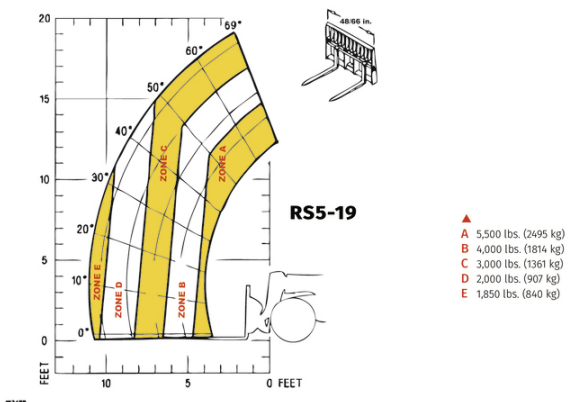

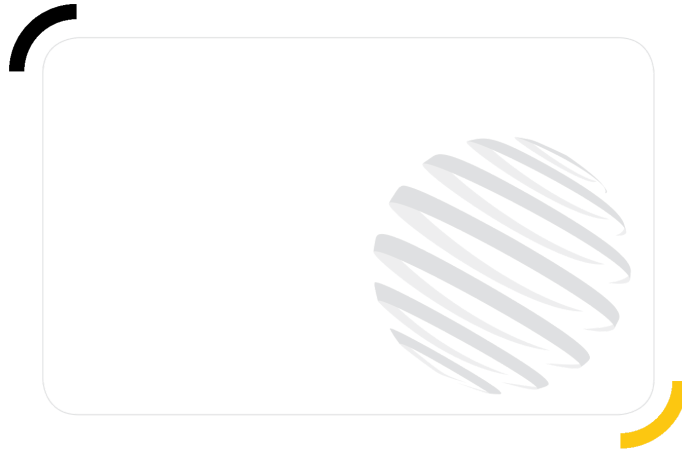

GEHL®

Siège Social
P.O. Box 179 - One Gehl Way - West Bend, WI, USA 53095
Tel: (262) 334-9461 - Fax: (262) 338-7517
www.gehl.com



This brochure describes versions and configuration options for Gehl products which may be fitted with different equipment. The equipment described in this brochure may be standard, optional or not available depending on version. Gehl reserves the right to change the specifications shown and described at any time and without prior warning. The manufacturer is not liable for the specifications given. For more information, contact your Gehl dealer. Non-contractual document. Product descriptions may differ from actual products. List of specifications is not comprehensive. The logos and visual identity of the company are the property of Gehl and may not be used without authorization. All rights reserved. The photos and diagrams contained in this brochure are provided for information only.

MANITOU EQUIPMENT AMERICAS, LLC - Limited company with board of directors - Share capital: 39,668,399 euros - 857 802 508 RCS West Bend