915E

EXCAVATOR

Engine

Cummins QSB4.5 Tier 4 Final

Gross Power

121 hp (90 kW)

Operating Weight

35,935 lb (16,300 kg)

Bucket Capacity

0.47 yd³ (0.36 m³)



TOUGH WORLD. TOUGH EQUIPMENT.

UNBEATABLE RETURN ON YOUR INVESTMENT

LiuGong's **customer-driven** design and **quality-focused** engineering creates lasting value that will deliver to your bottom line.

DEPENDABLE POWER

Unmatched performance driven by the Cummins QSB4.5 Tier 4 Final Engine.

IPC (INTELLIGENT POWER CONTROL)

IPC ensures the mechanical, electrical, and hydraulic systems work in perfect harmony for efficient precise control. Maximizing torque outlet with more power and breakout force.

AUTO-IDLE SPEED FUNCTION

Hydraulic signals detect activity, decreasing, and increasing engine speed as required. Power is supplied only as needed, achieving optimum fuel efficiency.

VERSATILITY

Options for auxiliary hydraulic piping include bi-directional variable high flow lines, an additional line for rotating attachments and a single acting line. The quick coupler further ensures you get the most out of your machine by easily switching between a wide range of attachments to suit your needs.



BOOM AND ARM

Boom and arm structures are designed for long-term durability and resistance to bending and torsional stress. Large cross-sectional areas incorporate one-piece steel castings to provide improved strength and standard rock guard plates and vertical guards further protect the arm in rocky conditions.

UNDERCARRIAGE

Outstanding stability and durability come from an X-type reinforced frame and the long track beam and crawler system.

REAR VIEW CAMERA

Like an extra eye outside the machine, the standard rear view camera sends images to the in-cab color LCD monitor, creating a safer working environment as you concentrate on the work at hand.

PARTS

Using genuine LiuGong parts is key to keeping your costs low and your machine in top working order. Our extensive support network is always there when you need it, to maximize your business profitability.

AFTER SALES SERVICE

As a customer of LiuGong you can feel confident that our dealers and regional offices will be there to support you with training, service and maintenance needed throughout the life of your machine.



DESIGNED TO GET MORE DONE

The 915E is designed to **get more done** in less time. Featuring a stronger boom, arm and bucket breakout force, greater hydraulic flow, higher swing speeds and improved cycle times, this excavator will power **through any task** in any terrain.

POWERFUL PERFORMANCE

The Cummins QSB4.5 engine produces gross power of 90 kW (121 hp) and torque of 470 N-m (347 lb-ft). LiuGong has harnessed this power for six working modes to the job at hand and even the least experienced of operators will find they can work faster and complete more in less time.

OPTIMIZED HYDRAULICS

Where intelligence meets brute force. Load-sensing hydraulics direct the engine's power to ensure hydraulic pump flow continually adjusts for smooth, quick, and efficient operation.

OPERATOR FRIENDLY ENVIRONMENT

Ergonomically designed controls, clear and informative displays, increased visibility, and exceptional comfort increases operator efficiency and safety.



EFFICIENCY, PRECISION & VERSATILITY

LiuGong E-Series excavators deliver the **perfect balance** of performance, precision, and quality. The 915E model is powered by the latest generation, low emissions Cummins QSB4.5 engine, with enhanced power output, **improved breakout force** and faster cycle times.

A POWERFUL ENGINE

Cummins QSB4.5 engine meets strict US EPA Tier 4 Final emissions standards. Delivering the greatest possible fuel economy without compromising on power.

Cummins designed integration system:

- Combustion technology
- Cummins Aftertreatment system
- EGR (Exhaust Gas Recirculation)
- VGT (Variable Geometry Turbocharger) improves boost across all engine speeds
- Cummins Tier 4 Final SCR (Selective Catalytic Reduction) technology increases engine performance, improves fuel economy while reducing exhaust emissions to US EPA Stringent Tier 4 Final standards.

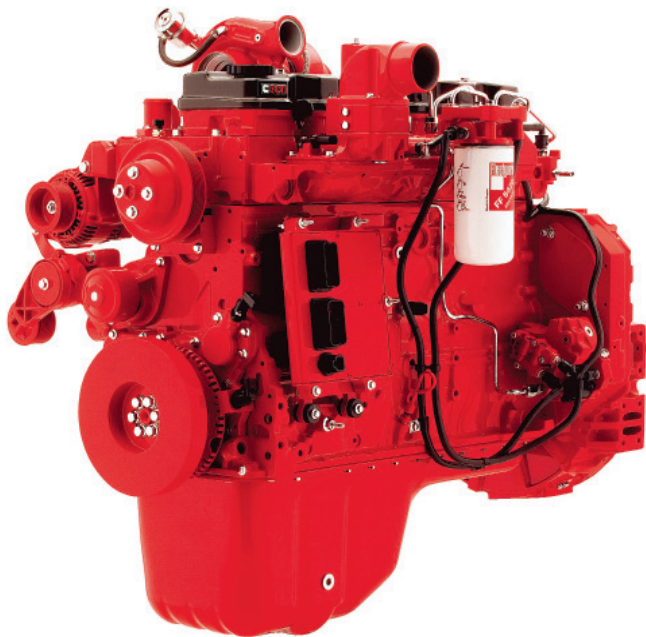

SAFETY STANDARDS

All LiuGong E-Series excavators come with certified ROPS (Rollover Protective System) cabs meeting ISO safety standards. LiuGong offers FOPS (Falling Object Protective Structure) as an option on all E-Series excavators.

ALL AROUND VISION FEATURES

LiuGong's E-Series cabs have seven percent larger glass surface area compared to our D-Series cab. Combined with standard rear view camera gives the operator a panoramic view. Combined with optional LED work lights provides clearer line of sight on jobsites.



ALL AROUND COMFORT

In the 915E cab, you're working in complete **comfort** with outstanding **visibility** all around. We understand how operators like to work and have designed the cab for **maximum comfort** and ultimate productivity.

AT HOME IN THE CAB

The E-Series cab is ROPS ISO 12117-2 certified mounted on dampener silicone to absorb noise and vibration. Wide spacious cab door swings full open to lock position. Front windshield slides up into ceiling, removable lower window, large roof skylight with sun screen.

ADVANCED CLIMATE CONTROL

Pressurized cab, advanced climate control, air is circulating through cab by ten outlets to improve air circulation and front windshield defrost allow year round operator comfort in any environment.

ADJUSTABLE SEAT AND JOYSTICK CONSOLE

The adjustable seat and joystick console move independently to accommodate the operator. Increased spacing between the armrest and nine different seat adjustments allow the operator more options to all foot and hand controls to maximum comfort.



MONITORING & SERVICING MADE EASY

LiuGong's new display interface can bring to the operator's attention **more features** than ever before.



ON BOARD MONITORING

LiuGong's new on board monitoring LCD display interface with audible sound alerts the operator to low fluid levels, high level machine warnings, and when maintenance service is needed. When fuel level is low, or DEF (Diesel Exhaust Fluid) is low, a text warning will appear where date and time is located on monitor. In addition, an audible buzz will sound to alert the operator to what action is needed. If this is a low-level fault, the buzz sound can be cancelled.



TRAVEL CAMERA STANDARD

When traveling in forward or reverse the display changes to a camera monitor. A camera mounted on rear of counterweight gives the operator an excellent view of what is behind the counterweight. This function can be accessed anytime by pressing the F3 switch.



MAINTENANCE MENU INTERFACE OPERATION

With easy access to the maintenance menu through our monitor, the operator can confirm which items should be checked 8 hours, 50 hours, and 100 hours up to 2000 hours.

Here you can easily track the various maintenance parameters of your machine to confirm your excavator is receiving the proper care which will extend the life of your machine.

ALWAYS STRONG ALWAYS RELIABLE

The use of thick, high-tensile steel components, internal baffling, and stress-relieved plates, make the structures on LiuGong E-Series excavators **tough and durable**.

We guarantee the **quality and reliability** of our machines throughout the manufacturing process by conducting stringent tests and ultrasound inspections that detect defects well before they make it into production.



BOOM & ARM

The boom and arm structures are designed with large cross-sectional supports and incorporates one-piece steel castings. Standard rock-guard plates and vertical guards protect the arm in rocky digging conditions and tough environments.

UPPER STRUCTURE

The upper structure is strongly reinforced by the use of an H-beam in the high cross section of the main structure providing even weight distribution and increasing stability.

The platform's collision protection system has been welded into place to improve its strength, rigidity and overall service life.



UNDERCARRIAGE

The high-strength undercarriage of the 915E incorporates a welded X-frame construction for long life durability and is designed to perform in the most challenging applications.

A long track beam and crawler system provides greater stability when using attachments for digging and truck loading. The result is outstanding strength and durability.

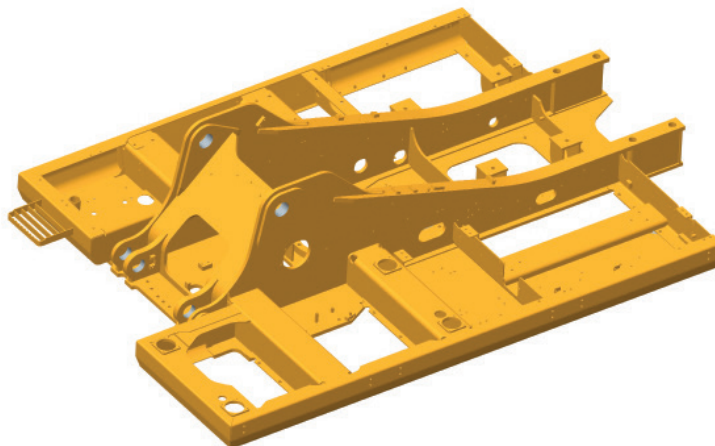

PART OF YOUR PERFORMANCE

LiuGong engineering sets high standards and all parts are rigorously tested to ensure they can meet the rigid quality specifications required for long lasting performance. No matter where you are in **North America**, we can ensure fast and efficient parts support to keep you going.



We know that confidence in your machine and those who support it is essential. At LiuGong North America we make sure we can always get what you need without delay, via our global parts depot, and the support of our local dealer network.

READY FOR ANY JOB

LiuGong provides a range of purpose designed attachments, hitches and tools for your 915E to give you increased versatility for any jobsite. In-cab dial-in hydraulic flow settings through the display screen optimizes the attachment performance.



BUCKETS



QUICK COUPLER



HAMMER

SPECIFICATIONS

ENGINE	
Description	
Cummins Tier 4 Final 4.5 liter 4-cylinder Variable-Geometry Turbocharger (VGT) Air Cleaner: Cummins direct flow air filter.	
Emissions rating	EPA Tier 4 Final / Stage IV
Make	Cummins
Model	QSB4.5
Aspiration	Variable-Geometry Turbocharger
Charged air cooling	Aftercooler
Cooling fan drive	Viscous clutch
Displacement	4.5 L (275 in ³)
Gross power	90 kW (121 hp) @ 2,200 rpm
Net power	84.3 kW (113 hp) @ 2,200 rpm
Peak torque	470 N-m (347 lb-ft) @ 1,500 rpm
Number of cylinders	4
Bore x Stroke	107 x 124 mm (4.2 x 4.9 in)
HYDRAULIC SYSTEM	
Main pump	
Type	Two variable displacement piston pumps
Maximum flow	2 x 120 L/min (31.7 gal/min)
Pilot pump	
Type	Gear pump
Maximum flow	19 L/min (5 gal/min)
Relief valve setting	
Implement	34.3/37.3 MPa (4,975 / 5,410 psi)
Travel circuit	34.3 MPa (4,975 psi)
Slew circuit	25.5 MPa (3,698 psi)
Pilot circuit	3.9 MPa (566 psi)
Hydraulic cylinders	
Boom Cylinder Bore x Stroke	105 mm x 1,500 mm (4.1 in x 4 ft 11 in)
Arm Cylinder Bore x Stroke	115 mm x 1,695 mm (4.5 in x 5 ft 7 in)
Bucket Cylinder Bore x Stroke	95 mm x 1,378 mm (3.7 in x 4 ft 6 in)
SERVICE CAPACITIES	
Fuel tank	245 L (65 gal)
Engine oil	11 L (2.9 gal)
Final drive (each)	2.5 L (0.66 gal)
Swing drive	3 L (0.79 gal)
Cooling system	21 L (5.5 gal)
Hydraulic reservoir	160 L (42.3 gal)
Hydraulic system total	240 L (63.4 gal)
DEF tank	16.9 L (4.5 gal)
UNDERCARRIAGE	
Track shoe each side	46
Link pitch	190 mm (7.5 in)
Shoe width, triple grouser	600 mm (24.0 in)
Bottom rollers each side	7
Top rollers each side	1
SWING SYSTEM	
Description	
Planetary gear reduction driven by high torque axial piston motor, with oil disk brake. Swing parking brake resets within five seconds after swing pilot controls return to neutral.	
Swing speed	12.9 rpm
Swing torque	80,800 N-m (59,595 lb-ft)
DRIVE AND BRAKES	
Description	
2-speed axial piston motors with oil disk brakes. Steering controlled by two detachable hand levers with pedals.	
Max. travel speed	High: 6.0 km/h (3.7 mph) Low: 3.5 km/h (2.2 mph)
Gradeability	35° / 70%
Max. drawbar pull	124 kN (27,876 lbf)
ELECTRIC SYSTEM	
System voltage	24V
Batteries	2 x 12V
Alternator	24V - 70A
Starter motor	24V - 4.8 kW (24V - 6.4 hp)
SOUND PERFORMANCE	
Interior sound level (ISO 6396)	70 dB(A)
Exterior sound level (ISO 6395)	100 dB(A)

SPECIFICATIONS

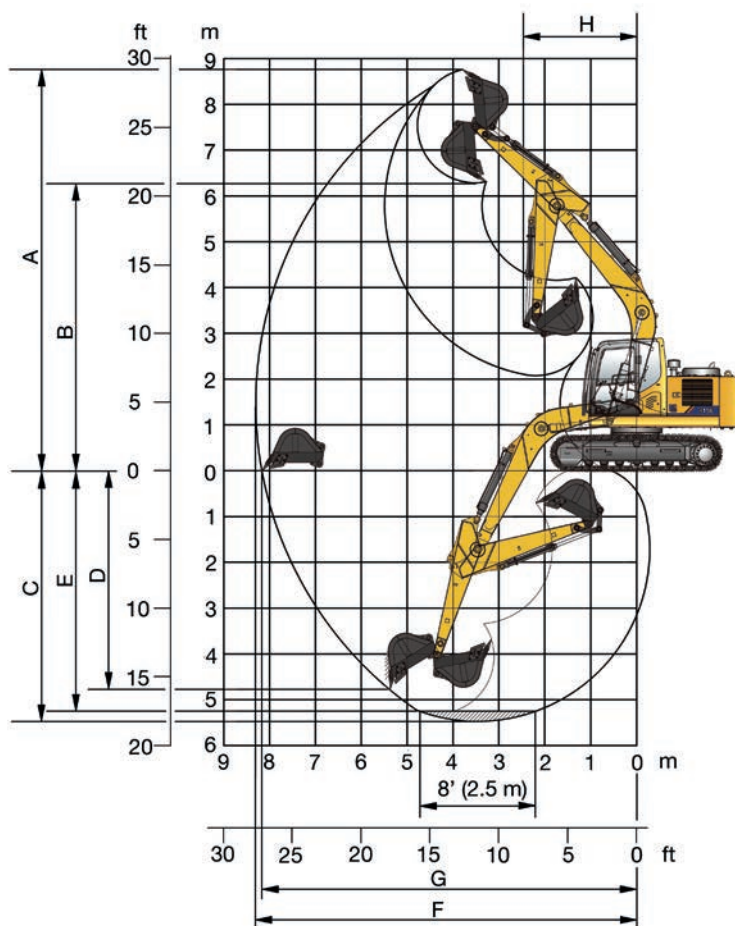

WORKING RANGES

Description		Standard Arm
Boom		4.6 m (15 ft 1 in)
Arm options		2.9 m (9 ft 6 in)
A Max. digging height		9,040 mm (29 ft 8 in)
B Max. dumping height		6,590 mm (21 ft 7 in)
C Max. digging depth		5,870 mm (19 ft 3 in)
D Max. vertical wall digging depth		5,160 mm (16 ft 11 in)
E Max. digging depth 2.4m (8 ft) level bottom		5,670 mm (18 ft 7 in)
F Max. digging reach		8,720 mm (28 ft 7 in)
G Max. digging reach at ground level		8,620 mm (28 ft 3 in)
H Min. swing radius		2,545 mm (8 ft 4 in)
Bucket digging force (ISO)	Normal	89.8 kN (20,188 lbf)
	Power boost	96.9 kN (21,784 lbf)
Arm digging force (ISO)	Normal	64.9 kN (14,590 lbf)
	Power boost	70 kN (15,737 lbf)
Bucket capacity		0.36 m ³ (0.47 yd ³)
Bucket tip radius		1,254 mm (4 ft 1 in)

SPECIFICATIONS

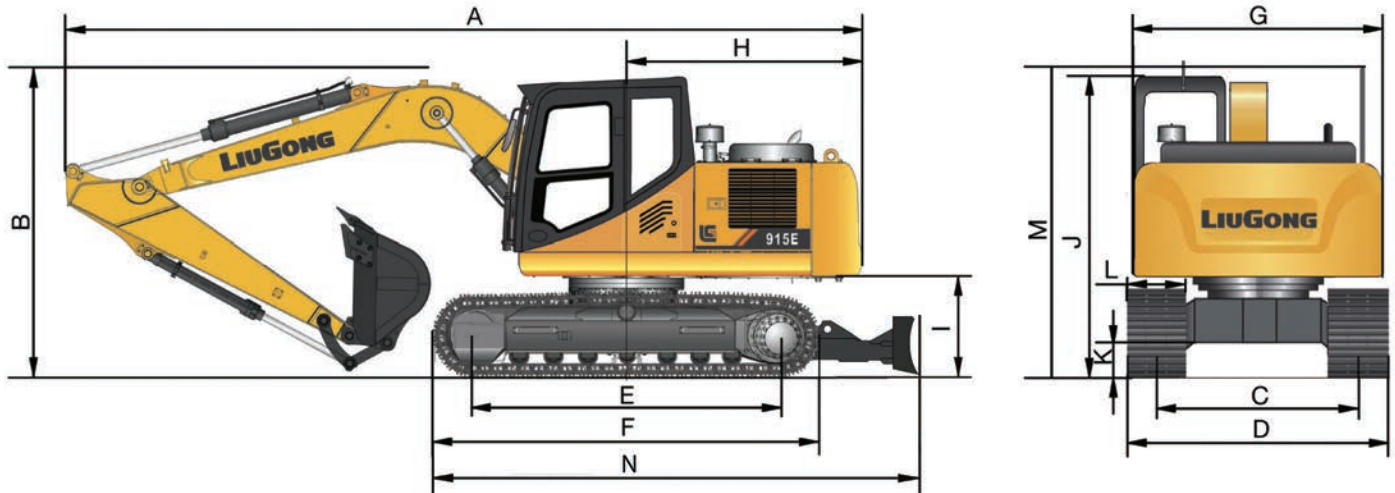

DIMENSIONS

	Standard Arm
Boom	4.6 m (15 ft 1 in)
Arm options	2.9 m (9 ft 6 in)
A Shipping length	7,750 mm (25 ft 5 in)
B Shipping height top of boom	3,055 mm (10 ft 0 in)
C Track gauge	1,990 mm (6 ft 6 in)
D Undercarriage width	2,590 mm (8 ft 6 in)
E Length to center of rollers	3,010 mm (9 ft 10 in)
F Track length	3,746 mm (12 ft 3 in)
G Overall width of upper structure	2,490 mm (8 ft 2 in)
H Tail swing radius	2,305 mm (7 ft 7 in)
I Counterweight ground clearance	960 mm (3 ft 2 in)
J Overall height of cab	3,055 mm (10 ft 0 in)
K Min. ground clearance	430 mm (1 ft 5 in)
L Track shoe width	600 mm (24.0 in)
M Height to top of hand rail	2,940 mm (9 ft 8 in)
N Track length with blade	4,716 mm (15 ft 6 in)

SPECIFICATIONS

915E WITH 600 MM (24.0 IN) SHOES, 2.9 M (9 FT 6 IN) ARM

- A: Reach from swing center
- B: Bucket hook height
- C: Lifting capacity
- Cf: Rating over front
- Cs: Rating over side

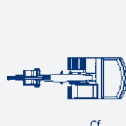

Conditions:
 Boom length: 4.6 m (15 ft 1 in)
 Arm length: 2.9 m (9 ft 6 in)
 Counterweight: 2,300 kg (5,071 lb)
 Shoes: 600 mm (24.0 in)
 Bucket: SAE 0.36 m³ (0.47 yd³), 390 kg (860 lb)

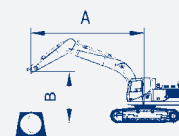

BLADE DOWN

A Reach: m (ft)

B: Height m (ft)		1.5 m (5 ft)		3 m (10 ft)		4.5 m (15 ft)		6 m (20 ft)		MAX REACH		
		Cf	Cs	Cf	Cs	Cf	Cs			Front	Side	Distance
6 m	kg					*2,710	*2,710			*1,520	*1,520	5.2 m
20 ft	lb					*5,975	*5,975			*3,351	*3,351	17 ft 1 in
4.5 m	kg					*2,940	*2,940	*2,040	*2,040	*1,470	*1,470	6.2 m
15 ft	lb					*6,482	*6,482	*4,497	*4,497	*3,240	*3,240	20 ft 3 in
3 m	kg			*5,050	*5,050	*3,630	3,360	*3,050	2,050	*1,250	*1,250	6.8 m
10 ft	lb			*11,133	*11,133	*8,003	7,408	*6,724	4,519	*2,756	*2,756	22 ft 3 in
1.5 m	kg			*7,390	6,230	*4,490	3,140	*3,400	1,960	*2,180	1,590	6.8 m
5 ft	lb			*16,292	13,735	*9,899	6,923	*7,496	4,321	*4,806	3,505	22 ft 3 in
0 m	kg			*8,280	5,940	*5,070	2,980	*3,640	1,880	*1,700	1,540	6.8 m
0 ft	lb			*18,254	13,095	*11,177	6,570	*8,025	4,145	*3,748	3,395	22 ft 3 in
-1.5 m	kg	*5,510	*5,510	*7,920	5,910	*5,100	2,930	*3,550	1,860	*2,940	1,770	6.2 m
-5 ft	lb	*12,147	*12,147	*17,461	13,029	*11,244	6,460	*7,826	4,101	*6,482	3,902	20 ft 3 in
-3 m	kg	*8,750	*8,750	*6,640	6,000	*4,370	2,960			*3,540	2,370	5.2 m
-10 ft	lb	*19,290	*19,290	*14,639	13,228	*9,634	6,526			*7,804	5,225	17 ft 1 in

BLADE UP

6 m	kg					*2,710	*2,710			*1,520	*1,520	5.2 m
20 ft	lb					*5,975	*5,975			*3,351	*3,351	17 ft 1 in
4.5 m	kg					*2,940	*2,940	*2,040	*2,040	*1,470	*1,470	6.2 m
15 ft	lb					*6,482	*6,482	*4,497	*4,497	*3,240	*3,240	20 ft 3 in
3 m	kg			*5,050	*5,050	*3,630	3,360	2,580	2,050	*1,250	*1,250	6.8 m
10 ft	lb			*11,133	*11,133	*8,003	7,408	5,688	4,519	*2,756	*2,756	22 ft 3 in
1.5 m	kg			*7,390	6,230	4,010	3,140	2,490	1,960	2,020	1,590	6.8 m
5 ft	lb			*16,292	13,735	8,841	6,923	5,490	4,321	4,453	3,505	22 ft 3 in
0 m	kg			8,090	5,940	3,840	2,980	2,410	1,880	1,700	1,540	6.8 m
0 ft	lb			17,835	13,095	8,466	6,970	5,313	4,145	3,748	3,395	22 ft 3 in
-1.5 m	kg	*5,510	*5,510	*7,920	5,910	3,780	2,930	2,390	1,860	2,700	1,770	6.2 m
-5 ft	lb	*12,147	*12,147	*17,461	13,029	8,333	6,460	5,269	4,101	5,952	3,902	20 ft 3 in
-3 m	kg	*8,750	*8,750	*6,640	6,000	3,830	2,960			3,030	2,370	5.2 m
-10 ft	lb	*19,290	*19,290	*14,639	13,228	8,444	6,526			6,680	5,225	17 ft 1 in

1. * Indicates the load is limited by hydraulic capacity rather than the tipping capacity.
2. The above loads are in compliance with the ISO 10567 hydraulic rating standard. They do not exceed 87% of the hydraulic lifting capacity of 75% tipping load.
3. Rating at bucket lift hook.

SPECIFICATIONS

MACHINE WEIGHTS AND GROUND PRESSURE

Operating weight includes boom 4.6 m (15 ft 1 in), arm 2.9 m (9 ft 6 in), bucket 0.36 m³ (0.47 yd³) counterweight 2,300 kg (5,071 lb) full fuel tank, and operator.

Shoe Width	Operating Weight	Ground Pressure	Overall Width
600 mm	16,300 kg	40.3 kPa	2,590 mm
24.0 in	35,935 lb	5.8 psi	8 ft 6 in

Boom



Arm

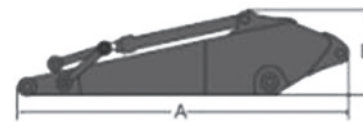

BOOM DIMENSIONS

Description

Standard

Boom	4.6 m (15 ft 1 in)
Length	4,760 mm (15 ft 7 in)
Height	1,667 mm (5 ft 6 in)
Width	565 mm (1 ft 10 in)
Weight	842 kg (1,856 lb)
Includes cylinder, piping and pin, excludes boom cylinder pin.	

ARM DIMENSIONS

Description

Standard

Arm	2.9 m (9 ft 6 in)
Length	3,659 mm (12 ft 0 in)
Height	704 mm (2 ft 4 in)
Width	256 mm (10 in)
Weight	392 kg (864 lb)
Includes cylinder, piping and pin, excludes boom cylinder pin.	

BUCKET SELECTION GUIDE

Bucket Type	Capacity	Cutting Width	Weight	Teeth Pcs	HD Boom 4.6 m (15 ft 1 in) Shoes 600 mm (24.0 in)	
Heavy Duty	0.36 m ³ (0.47 yd ³)	748 mm (30 in)	576 kg (1,270 lb)	4	<input checked="" type="checkbox"/>	<input type="checkbox"/>

Maximum material density

◇ Used with material weights 1,200 - 1,300 kg/m³ (2,023 - 2,191 lb yd³) Coal, Caliche, Shale

□ Used with material weights up to 1,400 - 1,600 kg/m³ (2,360 - 2,697 lb yd³) wet earth and clay, Limestone, Sandstone

X Not Recommended

STANDARD EQUIPMENT

ENGINE

- Cummins QSB4.5 certified to stringent US EPA Tier 4 Final emissions standards
- Auto idle speed control
- 2 Stage air filters with pre-cleaner
- VGT (Variable Geometry Turbocharger)
- Fuel system pre-filter with water separator
- Radiator, oil cooler and intercooler
- IPC (Intelligent Power Control) system
- Engine overheating prevention system

HYDRAULIC SYSTEM

- Manual power boost
- Auto power boost
- Boom and arm regeneration circuits
- Pilot oil filter
- Pilot control shut-off lever
- Swing with anti-reverse function
- Control pattern changer valve
- Bi-directional piping to arm
- 2-joystick with multi buttons

TELEMATICS

- 36 months service from initial sale
- Positioning and engine on/off history

OPERATOR STATION

- Travel rear-view camera
- 3 hallogen work lights
- Pressurized and sealed cab with all around visibility
- Front window wiper
- Removable lower window
- 6-working mode selection system: Power Mode, Economy Mode, Fine Mode, Lifting Mode, Breaker Mode and Attachment Mode
- Skylight rooftop
- Air conditioner, heater, defroster
- AM/FM Radio with MP3 audio jack
- Color LCD monitor with alarms, filter/fluid change, fuel rate, water temperature, work mode, fault code, working hour, seven language setting
- Glass-breaking hammer
- Fire extinguisher
- Cup holder
- Floor mat
- Storage box
- Rotation beacon
- Front glass lower guard
- Travel alarm
- Front window rain guard

UPPER STRUCTURE

- Rear view mirror (right & left side)
- 2 batteries
- One key for all locks
- Fuel gauge
- Hydraulic oil level gauge
- Storage box
- Swing parking brake
- Boom working lights
- Light integrated into storage box
- Rollover Protective System (ROPS) Cab

UNDERCARRIAGE

- 600 mm (24.0 in) triple grouser track-shoes
- 1 piece track-guard (each-side)
- Towing eye on base frame
- Sealed and lubricated track chain

WORK EQUIPMENT

- 4.6 m (15 ft 1 in) boom
- 2.9 m (9 ft 6 in) arm
- 0.36 m³ (0.47 yd³) bucket heavy duty

OPTIONAL EQUIPMENT

ENGINE SYSTEM

- Electrical fuel refilling pump

HYDRAULIC SYSTEM

- Security valves (2 on boom and 1 on arm) Auxiliary Hydraulic options
- PTO rotating piping
- Hi pressure quick coupler piping

OPERATOR STATION

- Power outlet 24V to 12V converter
- 3 LED working lights
- Air suspension seat
- Falling Object Protective Structure (FOPS)

UNDERCARRIAGE

- 1 piece track-guard (each side)

FEATURES TO ENHANCE YOUR PRODUCTIVITY

- LED lights
- Attachment piping
- FOPS & rock guard
- Auto lube system



TOUGH WORLD. TOUGH EQUIPMENT.

LiuGong Construction Machinery N.A, LLC.

22220 Merchants Way - Suite 100
Katy, TX 77449
USA

T: 281-579-8882 F: 281-579-8388
www.liugongna.com

Like and follow us:



LG-PB-915E-012020-ENG-US

The LiuGong series of logos herein, including but not limited to word marks, device marks, letter of alphabet marks and combination marks, as the registered trademarks of Guangxi LiuGong Group Co., Ltd. are used by Guangxi LiuGong Machinery Co., Ltd. with legal permission, and shall not be used without permission. Specifications and designs are subject to change without notice. Illustrations and pictures may include optional equipment and may not include all standard equipment. Equipment and options varies by regional availability.