

2025G-C

3-SERIES FORKLIFT

ENGINE
Kubota WG2503 2.5 L

RATED POWER
46 / 2,700 kw/rpm

CAPACITY
5,000 lb



SPECIFICATIONS

GENERAL

Power type	2	LPG
Base capacity	3	5,000 lb
Load center	4	24 in

WEIGHTS

Service weight	5	unloaded	8,140 lb
Axle load	6	loaded / unloaded, front	11,867 / 2,849 lb
	7	loaded / unloaded, rear	1,773 / 5,291 lb

TIRES

Tire type	8	Cushion	
Wheels	9	front / rear	2 / 2
Wheelbase	10	58.5 in	
Tire size	11	front	21 x 7-15
	12	rear	16 x 5 x 10-1/2
Tread width	13	front / rear	35.0 / 36.2 in

MAST

Max. fork height	14	with std 2-stage mast	118.1 in
Free lift	15	with std 2-stage mast	5.5 in
Height, upright lowered	16	with std 2-stage mast	83.9 in
Height, upright extended	17	with std 2-stage mast	161.3 in
Mast tilt, fwd, back	18	with std 2-stage mast	6° / 12°
Carriage	19	width	36.2 in
Fork spread	20	minimum / maximum	8.7 / 34.7 in
Fork dimensions	21	T x W x L	1.6 x 4.8 x 42.1 in

CHASSIS

Length to fork face	22	with std 2-stage mast	94.1 in
Overall width	23	43.3 in	
Overhead guard height	24	83.5 in	
Turning radius	25	minimum outside	76.8 in
Fork overhang	26	with std 2-stage mast	16.7 in
Right angle stack	27	add load length and clearance	143.7 in
Ground clearance	28	minimum loaded	3.5 in
	29	center of wheelbase	5.5 in

Performance

Travel speed	30	loaded / unloaded	17 / 17.5 km/h
Lift speed	31	loaded / unloaded	0.60 / 0.65 m/s
Lower speed	32	loaded / unloaded	0.50 / 0.50 m/s
Max. drawbar pull	33	loaded	4,400 lb
Max. gradeability	34	loaded / unloaded	35 / 22 %

Systems

Brakes	35	service	Foot / hyd
	36	parking	Hand / mech
Engine	37	manufacturer	Kubota
	38	model	WG2503
	39	emission compliance	EPA 4F
	40	cylinders	4
	41	displacement	2.5 liter
	42	rated power	46 / 2,700 kw/rpm
	43	max. torque	168 / 1,600 N.m/rpm

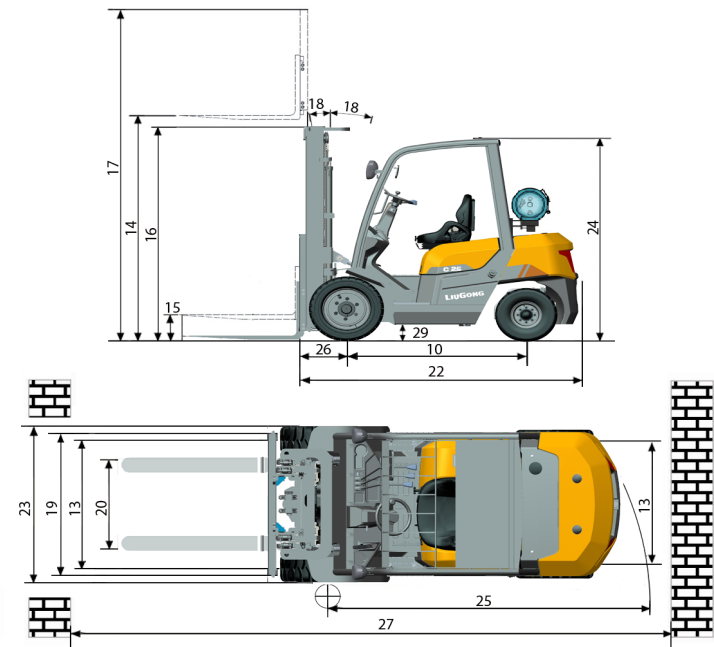

SPECIFICATIONS

EXCLUSIVELY FOR DEALER

CAPACITY - STANDARD 2-STAGE

Maximum fork height (MFH)	118.1 in (3,000 mm)
Mast overall lowered height (OAL)	83.9 in (2,130 mm)
Free lift with load backrest	5.5 in (140 mm)
Mast tilt angle (F/B)	6° / 12°
Rated load capacity with standard forks (@ 24in \500mm LC)	5,000 lb (2,500 kg)
Rated load capacity with side shifter (@ 24in \500mm LC)	5,000 lb (2,500 kg)
Total weight with standard forks	8,140 lb (3,700 kg)

CAPACITY - FULL FREE 3-STAGE

Maximum fork height (MFH)	177.2 in (4,500 mm)	185.0 in (4,700 mm)	196.9 in (5,000 mm)	216.5 in (5,500 mm)	236.2 in (6,000 mm)
Mast overall lowered height (OAL)	84.4 in (2,145 mm)	87.0 in (2,210 mm)	90.9 in (2,310 mm)	104.3 in (2,650 mm)	112.2 in (2,850 mm)
Free lift with load backrest	42.8 in (1,087 mm)	44.7 in (1,135 mm)	49.5 in (1,257 mm)	58.1 in (1,477 mm)	71.1 in (1,807 mm)
Mast tilt angle (F/B)	6° / 5°	6° / 5°	6° / 5°	6° / 5°	6° / 5°
Rated load capacity with standard forks (@ 24in \500mm LC)	4,905 lb (2,225 kg)	4,850 lb (2,200 kg)	4,740 lb (2,150 kg)	-	-
Rated load capacity with side shifter (@ 24in \500mm LC)	4,519 lb (2,050 kg)	4,464 lb (2,050 kg)	3,913 lb (1,775 kg)	-	-
Total weight with standard forks	8,444 lb (3,830 kg)	8,532 lb (3,870 kg)	8,653 lb (3,925 kg)	8,840 lb (4,010 kg)	8,984 lb (4,075 kg)



LiuGong Construction Machinery N.A., LLC.

22220 Merchants Way - Suite 100

Katy, TX 77449

USA

T: 281-579-8882

F: 281-579-8388

LiuGongNA.com



The LiuGong series of logos herein, including but not limited to word marks, device marks, letter of alphabet marks and combination marks, as the registered trademarks of Guangxi LiuGong Group Co., Ltd. are used by Guangxi LiuGong Machinery Co., Ltd. with legal permission, and shall not be used without permission. Specifications and designs are subject to change without notice. Illustrations and pictures may include optional equipment and may not include all standard equipment. Equipment and options vary by regional availability.

LGNA-SS-2025G-C-20211011-ENG-US